

# ALL TERRAIN 4020 MACH 1

**NOTES:**

2.59-4 PIN CAP THD PROTECTOR = 111-081  
 2.59-4 BOX PLUG THD PROTECTOR = 110-863

3.5-5 PIN CAP THD PROTECTOR = 110-933

2.875 API HIGH FLOW BEACON HOUSING  
 BOX PLUG THD PROTECTOR = 369-426

3.25-4 CAP THD PROTECTOR = 157-835  
 2.875-4 PLG THD PROTECTOR = 111-101  
 (THIS PROTECTOR WILL FIT 3.25-4F THDS)

368-379 CONNECTOR CAN BE USED TO PULL  
 MORE THAN ONE REAMER AT A TIME.

WRENCH SET IS FOR THE INSTALLATION AND  
 REMOVAL OF BITS ONLY.

CONNECTOR 220-051 ALLOWS THE USE OF 86B,  
 86BH, AND 86BG IN AN 86BHL HOUSING.

040820

**NOZZLE CHART**

N1	N2	N3
{1/4 NPT}	{7/16-20}	{7/8-14}
SJ .070, 149-200 SJ .100, 149-201 SJ .150, 149-202 SJ .200, 149-203 SJ .250, 149-204	AJ .104, 159-291 DJ .104, 159-292 SJ .104, 159-293 PLUG, 159-294 AJ .074, 159-295 DJ .074, 159-296 SJ .074, 159-297 AJ .156, 159-422 SJ .188, 159-423	AJ .209", 159-396 SJ .209", 159-397 PLUG, 159-398 AJ .157", 159-404 SJ .157", 159-405 AJ .104", 159-407 SJ .104", 159-407

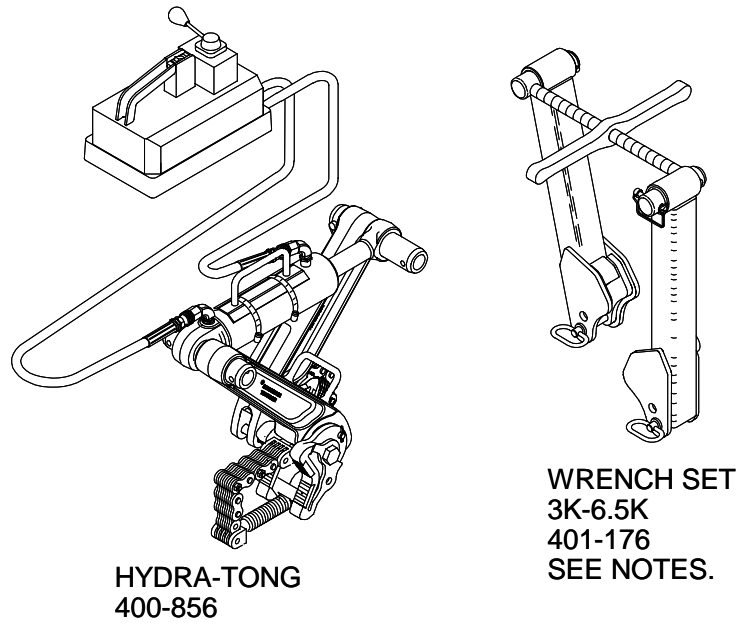
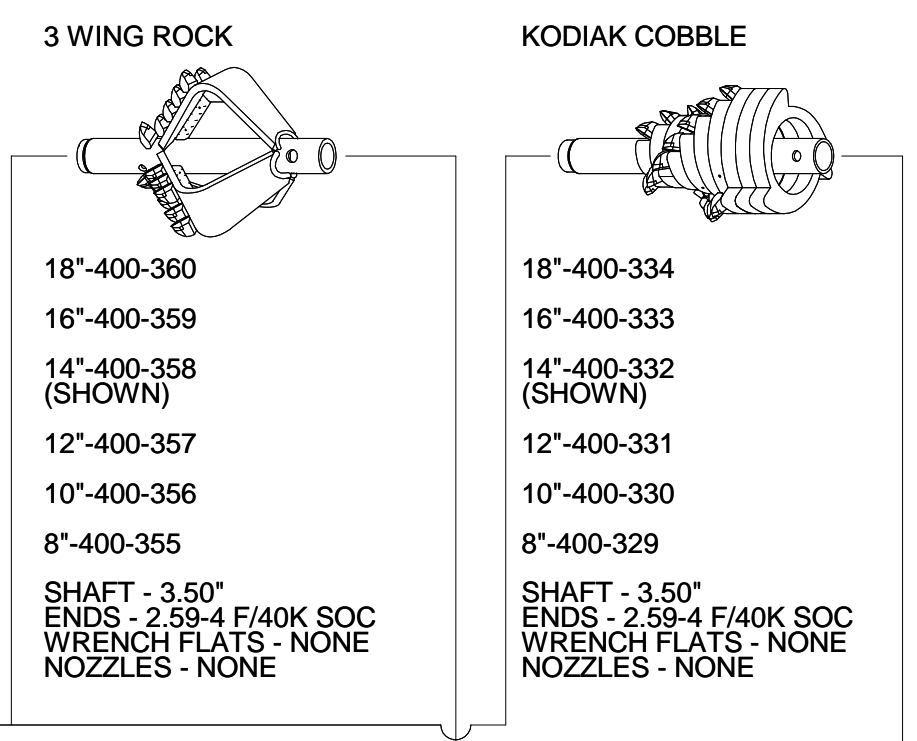
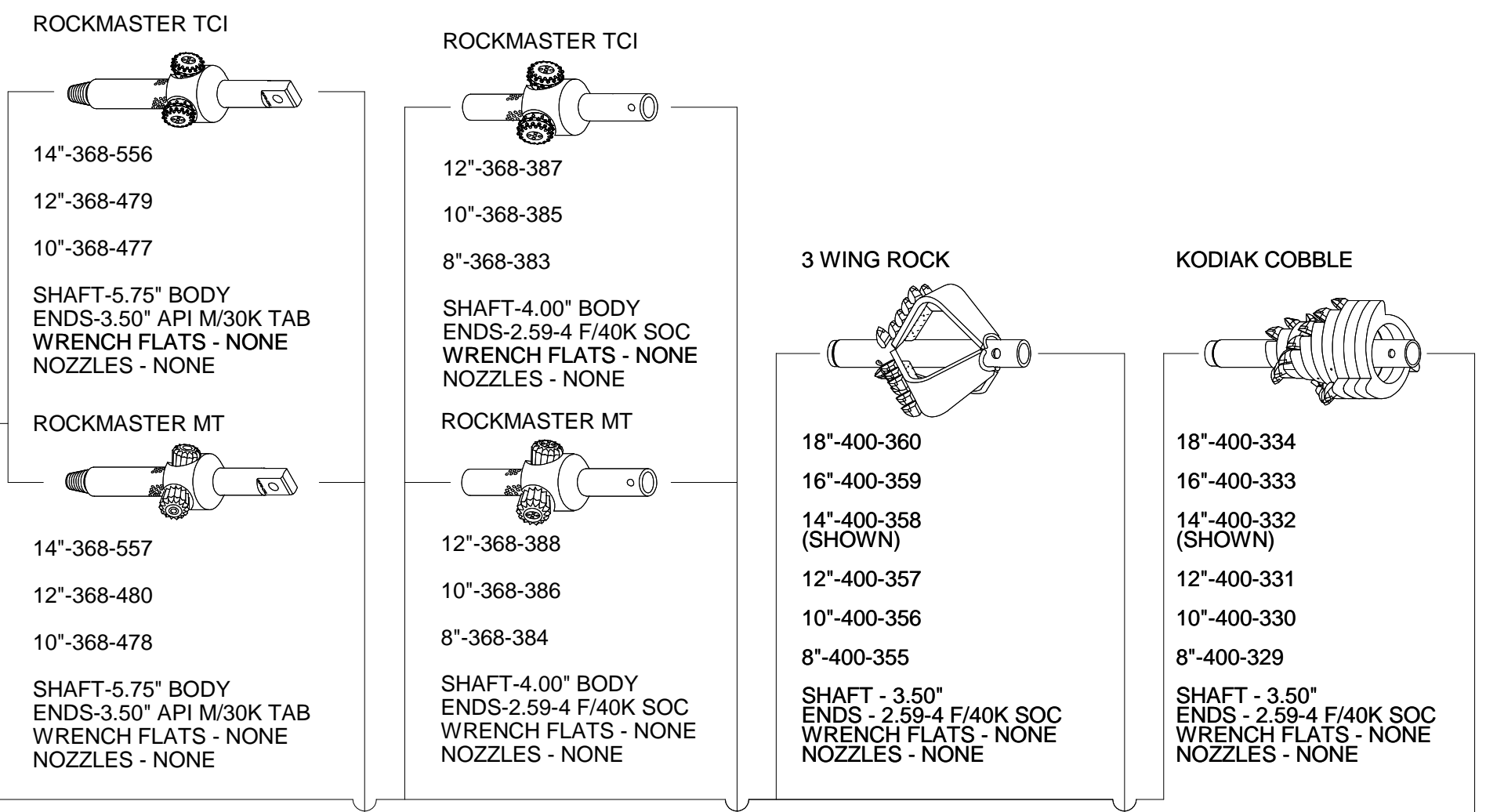
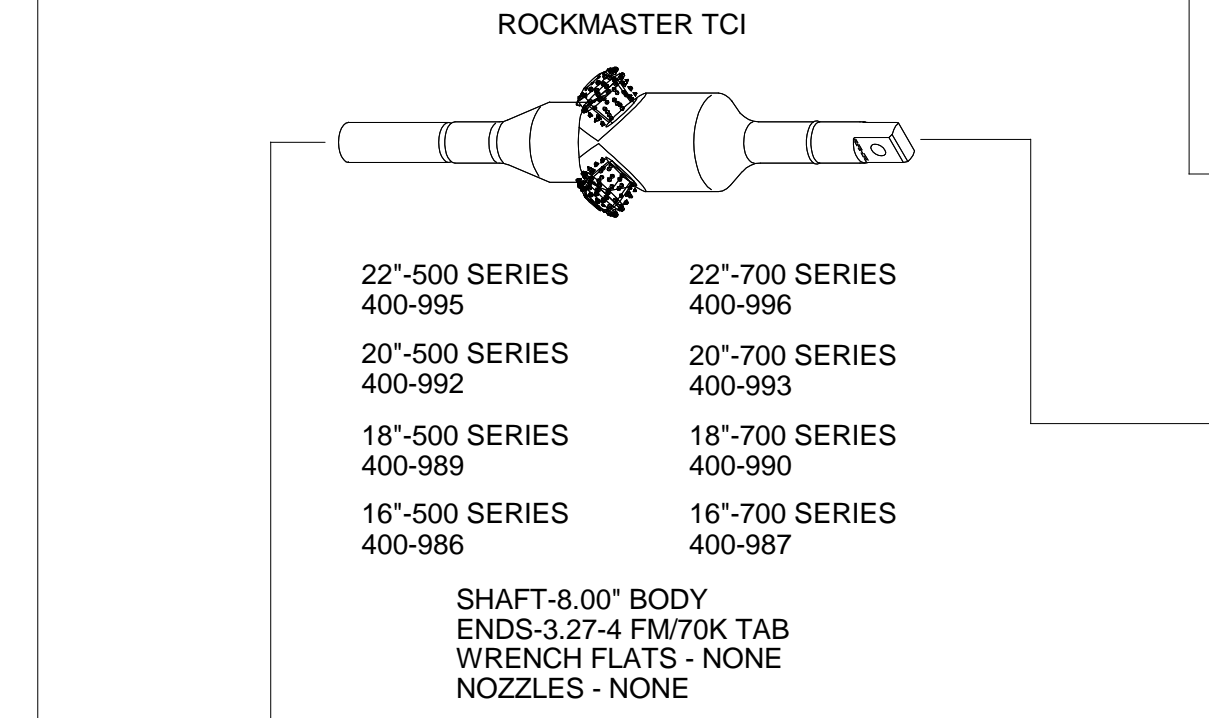
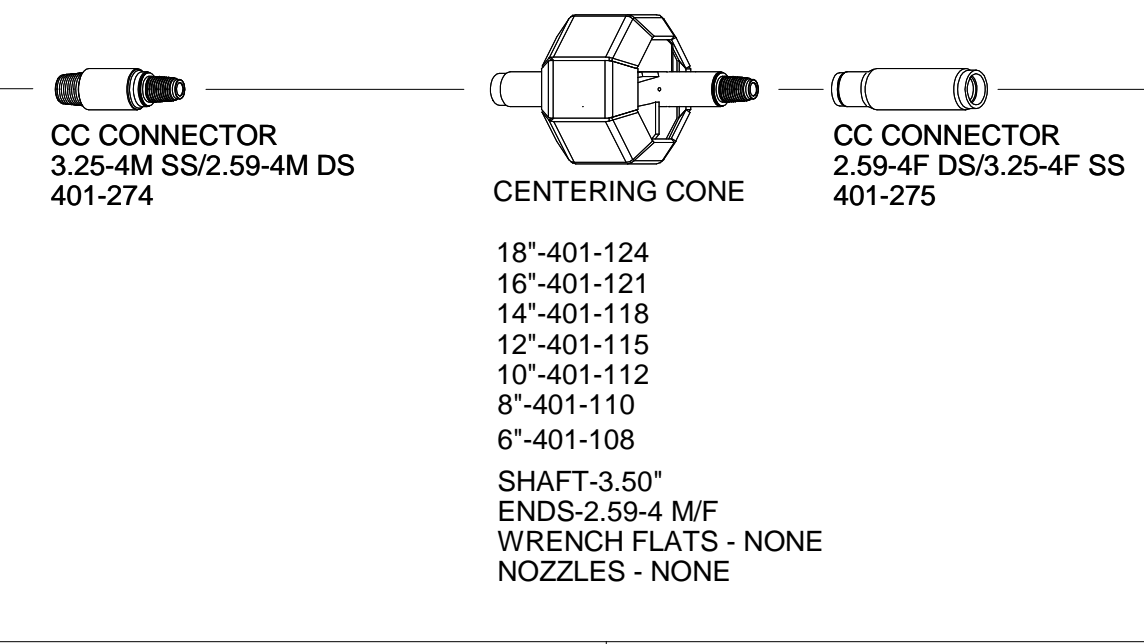

- WRENCH JAWS**
- FLATS JAW (4.50") 400-749
  - TRICONE JAW (6.25") 400-734
  - TRICONE JAW (6.25") 2.00" THK 401-133
  - TRICONE JAW (6.5") 2.00" THK 400-705
  - SPECIAL BIT JAW (6.25" SOFT FORMATION) 2.00" THK 401-148

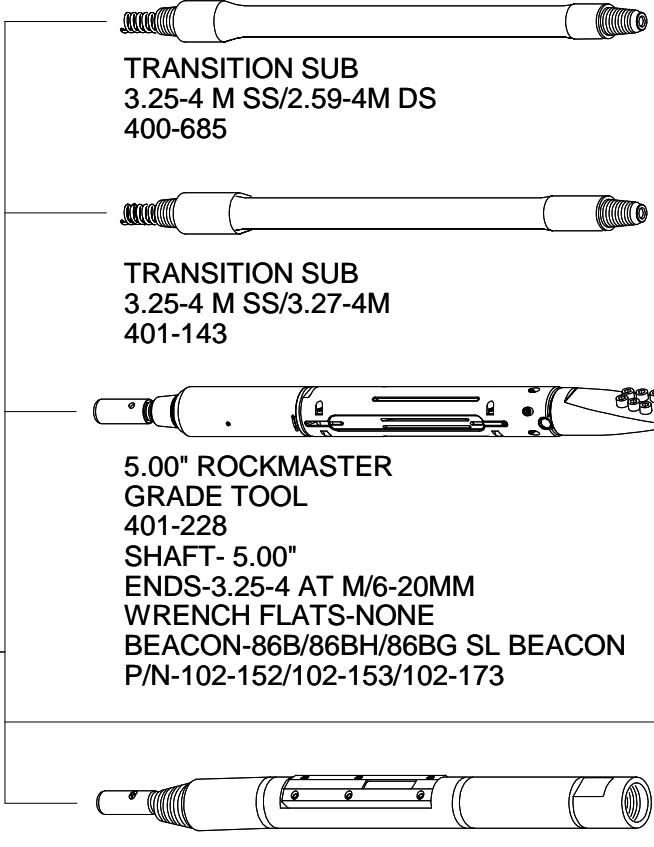
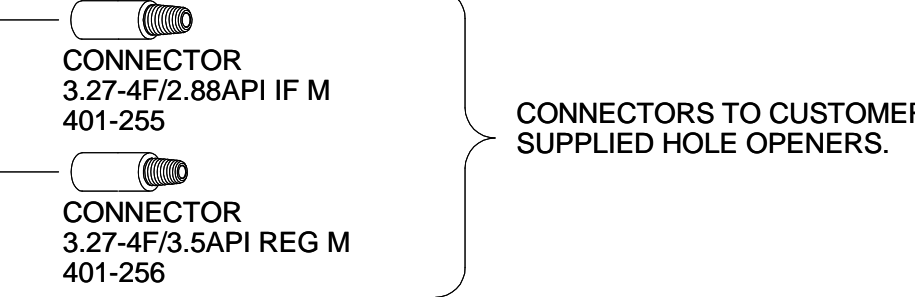

SEE JT4020M1 ROADMAP FOR AVAILABLE TOOLS

SEE JT4020M1 ROADMAP FOR AVAILABLE FLAT BITS

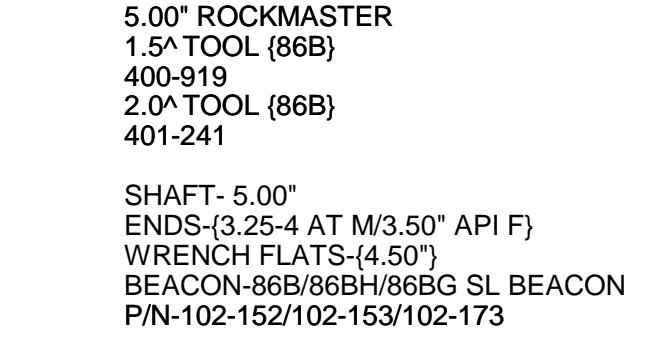

- |   |  |   |  |
|---|--|---|--|
| 6.25" TCI TRICONE (SEALED BEARING) 3.50 API M<br>VALUE BIT 700 SERIES 401-139<br>VALUE BIT 500 SERIES 401-138 | 6.50" TCI TRICONE (SEALED BEARING) 3.50 API M<br>NEW HDX30 SERIES 401-346<br>NEW XR40 SERIES 401-347<br>NEW HDS-3 SERIES 401-361 | 6.25" MT TRICONE (SEALED BEARING) 3.50 API M REGULAR<br>369-514 | SOFT FORMATION 3.50 API M<br>7.00" 400-683 |
|---|--|---|--|

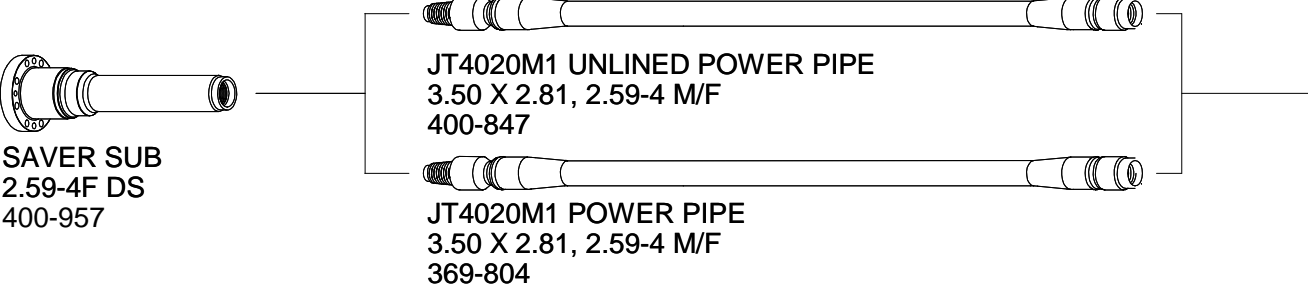
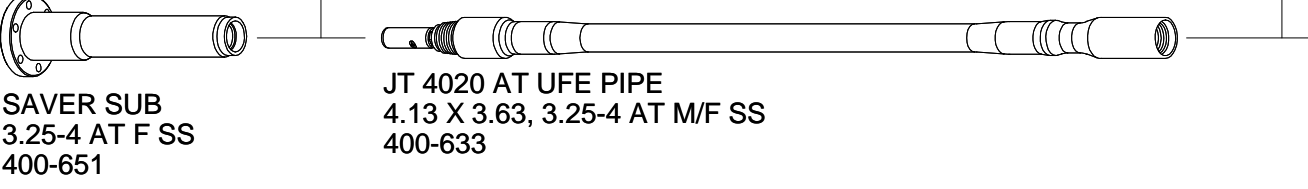

SEE JT4020M1 MAP FOR AVAILABLE DRILLING TOOLS

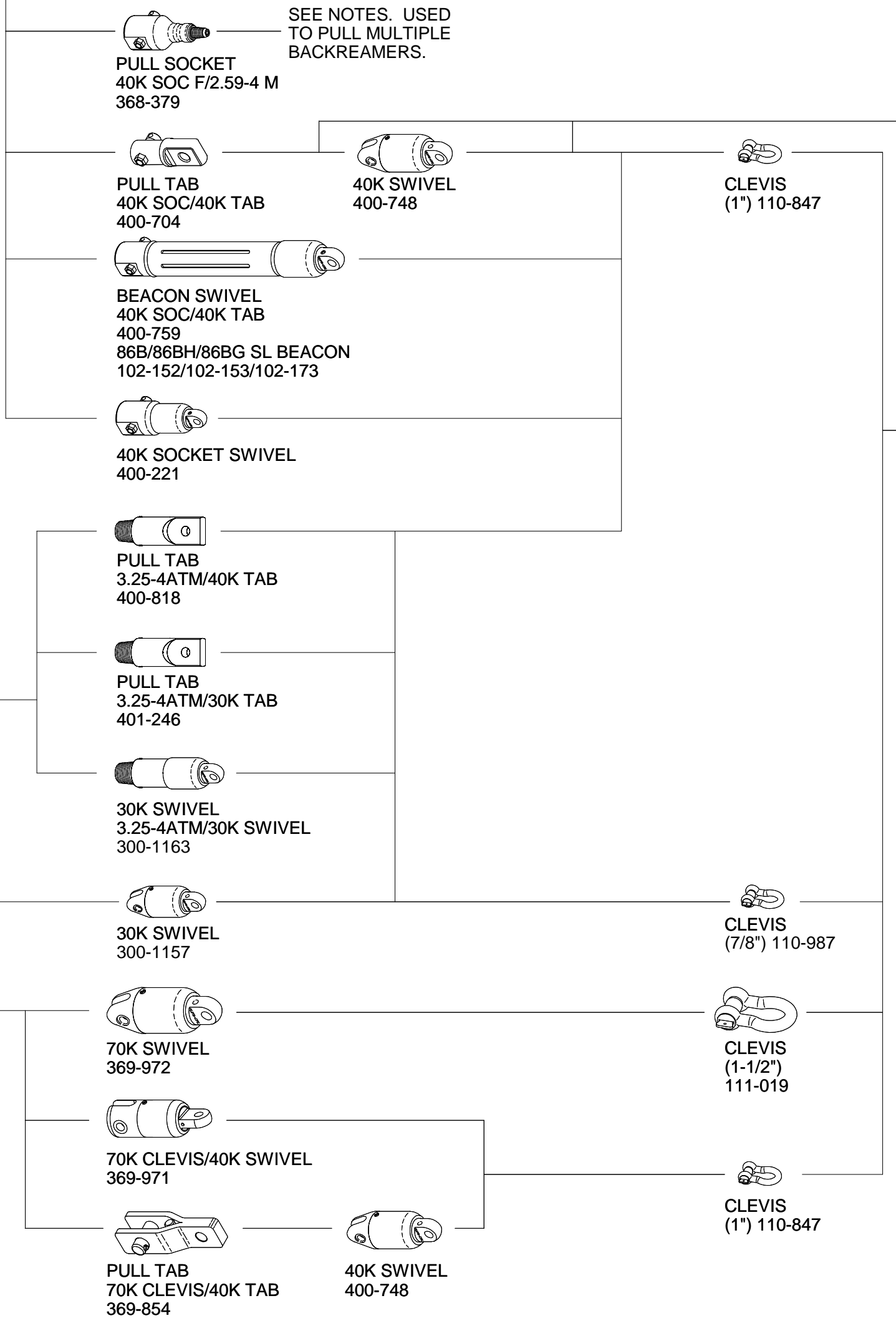

- 185-917 PULLING GRIP (3/4"-1-1/4")  
 185-918 PULLING GRIP (1-1/4"-2")  
 185-919 PULLING GRIP (2"-2-3/4")  
 185-920 PULLING GRIP (2-3/4"-3-1/2")  
 185-921 PULLING GRIP (3-1/2"-4-1/4")  
 185-922 HD PULLING GRIP (3/4"-1-1/4")  
 185-923 HD PULLING GRIP (1-1/4"-2")  
 185-924 HD PULLING GRIP (2"-2-3/4")  
 185-925 HD PULLING GRIP (2-3/4"-3-1/2")  
 185-926 HD PULLING GRIP (3-1/2"-4-1/4")

